

B(mm)	A(mm)	Deş(mm)
75	350	160
75	400	180
75	430	180
75	450	180
75	520	200
75	590	200
75	670	200
75	750	224
75	840	250
100	340	200
100	390	200
100	420	200
100	440	200
100	500	224
100	570	250
100	650	250
100	730	280
125	320	200
125	370	224
125	400	224
125	430	250
125	490	250
125	560	280
125	640	280
125	720	300
125	810	315
125	880	315
150	350	250
150	390	250
150	410	250
150	470	280
150	550	300
150	620	315
150	700	315
150	800	355
150	860	355
150	910	355
150	1030	400
150	1180	400
200	360	280
200	380	280
200	450	315
200	520	355
200	590	355
200	670	400
200	770	400
200	830	400
200	880	450
200	1010	450
200	1150	500
200	1310	500
250	350	300
250	420	355
250	490	355
250	570	400
250	640	400
250	740	450
250	800	450
250	850	500
250	980	500
250	1120	560
250	1280	560
250	1440	600
250	1630	630
250	1830	630

## OVAL KESİTLİ SPİRAL KENETLİ HAVALANDIRMA KANALI OVAL AIR DUCT WITH SPIRAL SEAM

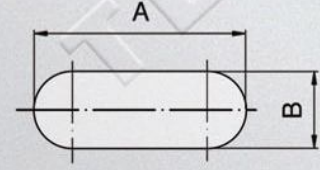

Oval hava kanalları, yuvarlak ve dikdörtgen kesitli hava kanallarının sahip olduğu avantajlara tek başına sahiptir. Kot problemi olan mimarilerde ideal ve estetik çözümler sunar. Yuvarlak yapılarından dolayı hava akışı daha laminar olduğundan daha az basınç kaybı olmaktadır. Sahip olduğu düşük yüzey alanı ve yüksek sızdırmazlık sistemin önemli avantajlarındandır. Ashrae tarafından eşdeğer çaplar aşağıda belirtildiği gibidir.

*Oval air ducts have advantages by itself which circular and rectangular air ducts have. Oval ducts systems present ideal and esthetic solutions at places which have a altitude problem. Because of their circular shapes, the air flow becomes more laminar so there will become less pressure drop. The low surface area and high leakproof are the important advantages of the oval duct systems. Below there are equivalence diameters made by Ashrae.*

B(mm)	A(mm)	Deş(mm)
300	460	400
300	540	400
300	620	450
300	710	500
300	770	500
300	820	500
300	950	560
300	1090	600
300	1250	630
300	1410	630
300	1600	710
300	1800	710
300	2040	800
350	510	450
350	590	450
350	680	500
350	750	560
350	790	560
350	920	600
350	1060	630
350	1220	710
350	1380	710
350	1570	710
350	1770	800
350	2010	800

B(mm)	A(mm)	Deş(mm)
400	560	500
400	650	560
400	720	560
400	760	560
400	890	630
400	1030	630
400	1190	710
400	1350	800
400	1540	800
400	1740	900
400	1980	900
450	530	500
450	620	560
450	690	560
450	730	600
450	860	630
450	1000	710
450	1160	710
450	1320	800
450	1510	900
450	1710	900
450	1950	1000
450	2010	1000

B(mm)	A(mm)	Deş(mm)
500	600	560
500	660	600
500	710	630
500	830	710
500	970	710
500	1120	800
500	1290	800
500	1480	900
500	1690	900
500	1920	1000
500	2080	1000
550	630	600
550	680	630
550	800	710
550	940	710
550	1100	800
550	1260	900
550	1450	900
550	1650	1000
550	1890	1000
550	2040	1120
600	650	630
600	770	710
600	910	800
600	1070	800
600	1230	900
600	1420	1000
600	1620	1000
600	1860	1120
600	2010	1120

- İzoleli imalatımız mevcuttur / These pieces can be isolated in our company
- Maksimum boy 3 m olacak şekilde imal edilir / They are produced with max length 3 m
- İstenilen boy, ebat ve renkte imalat vardır / It's also possible to produce every length, size and colour that customer needs.

B(mm)	A(mm)
75	350
75	400
75	430
75	450
75	520
75	590
75	670
75	750
75	840

100	340
100	390
100	420
100	440
100	500
100	570
100	650
100	730

125	320
125	370
125	400
125	430
125	490
125	560
125	640
125	720
125	810
125	880

150	350
150	390
150	410
150	470
150	550
150	620
150	700
150	800
150	860
150	910
150	1030
150	1180

200	360
200	380
200	450
200	520
200	590
200	670
200	770
200	830
200	880
200	1010
200	1150
200	1310

250	350
250	420
250	490
250	570
250	640
250	740
250	800
250	850
250	980
250	1120
250	1280
250	1440
250	1630
250	1830

**OVAL DİRSEK 90° (ZOR KIVRIM)**  
**OVAL ELBOW 90° (HARD BEND)**

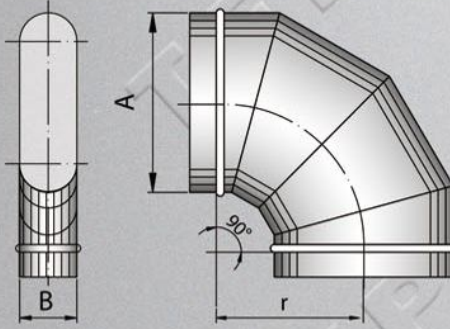

$$r = A$$

$$L = \tan 22,5^\circ \times r$$

**OVAL DİRSEK 90° (KOLAY KIVRIM)**  
**OVAL ELBOW 90° (EASY BEND)**

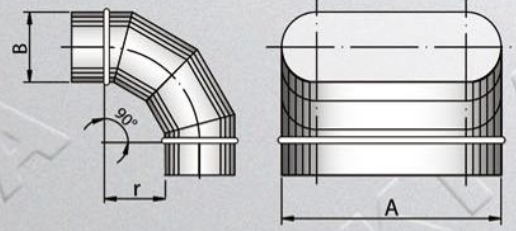

$$r = B$$

$$L = \tan 22,5^\circ \times r$$

B(mm)	A(mm)
-------	-------

300	460
300	540
300	620
300	710
300	770
300	820
300	950
300	1090
300	1250
300	1410
300	1600
300	1800
300	2040
350	510
350	590
350	680
350	750
350	790
350	920
350	1060
350	1220
350	1380
350	1570
350	1770
350	2010

B(mm)	A(mm)
-------	-------

450	530
450	620
450	690
450	730
450	860
450	1000
450	1160
450	1320
450	1510
450	1710
450	1950
450	2010
500	600
500	660
500	710
500	830
500	970
500	1120
500	1290
500	1480
500	1690
500	1920
500	2080

B(mm)	A(mm)
-------	-------

550	630
550	680
550	800
550	940
550	1100
550	1260
550	1450
550	1650
550	1890
550	2040
600	650
600	770
600	910
600	1070
600	1230
600	1420
600	1620
600	1860
600	2010

• Contalı ve contasız imalatımız mevcuttur  
/ The products can be produced with or without gasket

**TEKPA**

B(mm)	A(mm)
75	350
75	400
75	430
75	450
75	520
75	590
75	670
75	750
75	840
100	340
100	390
100	420
100	440
100	500
100	570
100	650
100	730
125	320
125	370
125	400
125	430
125	490
125	560
125	640
125	720
125	810
125	880
150	350
150	390
150	410
150	470
150	550
150	620
150	700
150	800
150	860
150	910
150	1030
150	1180
200	360
200	380
200	450
200	520
200	590
200	670
200	770
200	830
200	880
200	1010
200	1150
200	1310
250	350
250	420
250	490
250	570
250	640
250	740
250	800
250	850
250	980
250	1120
250	1280
250	1440
250	1630
250	1830

**OVAL DİRSEK 60° (ZOR KIVRIM)**  
**OVAL ELBOW 60° (HARD BEND)**

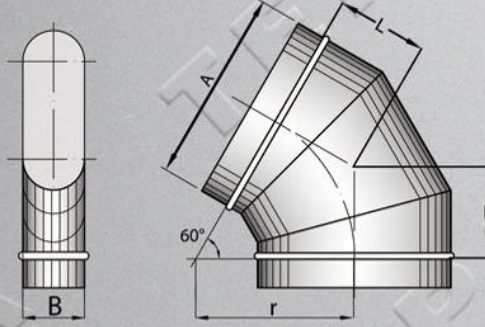

$$r = A$$

$$L = \tan 30^\circ \times r$$

**OVAL DİRSEK 60° (KOLAY KIVRIM)**  
**OVAL ELBOW 60° (EASY BEND)**

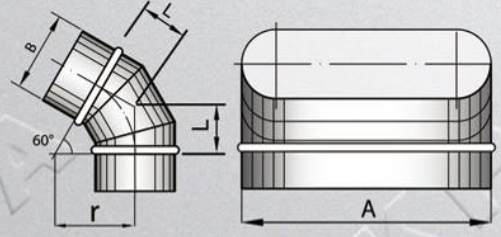

$$r = B$$

$$L = \tan 30^\circ \times r$$

B(mm)	A(mm)
300	460
300	540
300	620
300	710
300	770
300	820
300	950
300	1090
300	1250
300	1410
300	1600
300	1800
300	2040

B(mm)	A(mm)
450	530
450	620
450	690
450	730
450	860
450	1000
450	1160
450	1320
450	1510
450	1710
450	1950
450	2010

B(mm)	A(mm)
550	630
550	680
550	800
550	940
550	1100
550	1260
550	1450
550	1650
550	1890
550	2040
600	650
600	770
600	910
600	1070
600	1230
600	1420
600	1620
600	1860
600	2010



• Contalı ve contasız imalatımız mevcuttur  
The products can be produced with or without gasket

**TEKPA**

B(mm)	A(mm)
75	350
75	400
75	430
75	450
75	520
75	590
75	670
75	750
75	840
100	340
100	390
100	420
100	440
100	500
100	570
100	650
100	730
125	320
125	370
125	400
125	430
125	490
125	560
125	640
125	720
125	810
125	880
150	350
150	390
150	410
150	470
150	550
150	620
150	700
150	800
150	860
150	910
150	1030
150	1180
200	360
200	380
200	450
200	520
200	590
200	670
200	770
200	830
200	880
200	1010
200	1150
200	1310
250	350
250	420
250	490
250	570
250	640
250	740
250	800
250	850
250	980
250	1120
250	1280
250	1440
250	1630
250	1830

**OVAL DİRSEK 45° (ZOR KIVRIM)**  
**OVAL ELBOW 45° (HARD BEND)**

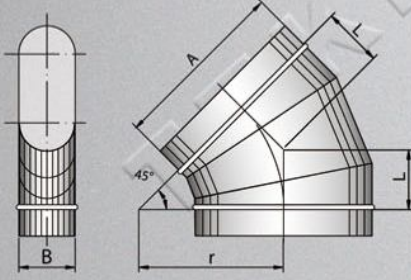

$r = A$   
 $L = \tan 22,5^\circ \times r$

**OVAL DİRSEK 45° (KOLAY KIVRIM)**  
**OVAL ELBOW 45° (EASY BEND)**

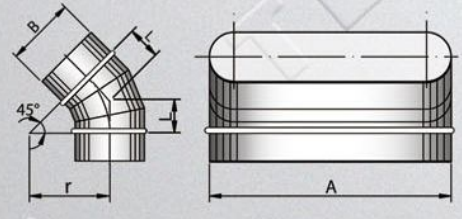

$r = B$   
 $L = \tan 22,5^\circ \times r$

B(mm)	A(mm)
300	460
300	540
300	620
300	710
300	770
300	820
300	950
300	1090
300	1250
300	1410
300	1600
300	1800
300	2040
350	510
350	590
350	680
350	750
350	790
350	920
350	1060
350	1220
350	1380
350	1570
350	1770
350	2010
400	560
400	650
400	720
400	760
400	890
400	1030
400	1190
400	1350
400	1540
400	1740
400	1980

B(mm)	A(mm)
450	530
450	620
450	690
450	730
450	860
450	1000
450	1160
450	1320
450	1510
450	1710
450	1950
450	2010
500	600
500	660
500	710
500	830
500	970
500	1120
500	1290
500	1480
500	1690
500	1920
500	2080

B(mm)	A(mm)
550	630
550	680
550	800
550	940
550	1100
550	1260
550	1450
550	1650
550	1890
550	2040
600	650
600	770
600	910
600	1070
600	1230
600	1420
600	1620
600	1860
600	2010



• Contalı ve contasız imalatımız mevcuttur  
 / The products can be produced with or without gasket

B(mm)	A(mm)
75	350
75	400
75	430
75	450
75	520
75	590
75	670
75	750
75	840
100	340
100	390
100	420
100	440
100	500
100	570
100	650
100	730
125	320
125	370
125	400
125	430
125	490
125	560
125	640
125	720
125	810
125	880
150	350
150	390
150	410
150	470
150	550
150	620
150	700
150	800
150	860
150	910
150	1030
150	1180
200	360
200	380
200	450
200	520
200	590
200	670
200	770
200	830
200	880
200	1010
200	1150
200	1310
250	350
250	420
250	490
250	570
250	640
250	740
250	800
250	850
250	980
250	1120
250	1280
250	1440
250	1630
250	1830

**OVAL DİRSEK 30° (ZOR KIVRIM)**  
**OVAL ELBOW 30° (HARD BEND)**

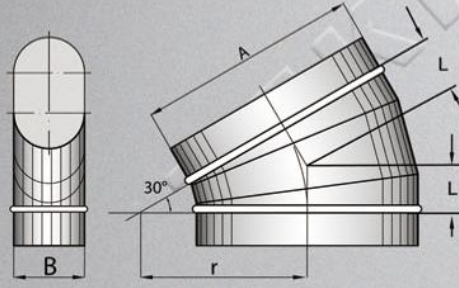

$r = A$   
 $L = \tan 15^\circ \times r$

**OVAL DİRSEK 30° (KOLAY KIVRIM)**  
**OVAL ELBOW 30° (EASY BEND)**

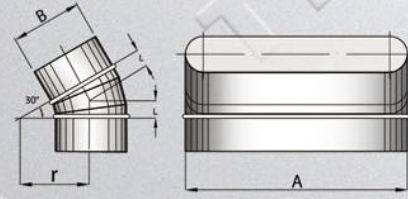

$r = B$   
 $L = \tan 15^\circ \times r$

B(mm)	A(mm)
300	460
300	540
300	620
300	710
300	770
300	820
300	950
300	1090
300	1250
300	1410
300	1600
300	1800
300	2040
350	510
350	590
350	680
350	750
350	790
350	920
350	1060
350	1220
350	1380
350	1570
350	1770
350	2010
400	560
400	650
400	720
400	760
400	890
400	1030
400	1190
400	1350
400	1540
400	1740
400	1980

B(mm)	A(mm)
450	530
450	620
450	690
450	730
450	860
450	1000
450	1160
450	1320
450	1510
450	1710
450	1950
450	2010
500	600
500	660
500	710
500	830
500	970
500	1120
500	1290
500	1480
500	1690
500	1920
500	2080

B(mm)	A(mm)
550	630
550	680
550	800
550	940
550	1100
550	1260
550	1450
550	1650
550	1890
550	2040
600	650
600	770
600	910
600	1070
600	1230
600	1420
600	1620
600	1860
600	2010



• Contalı ve contasız imalatımız mevcuttur  
 / The products can be produced with or without gasket

**OVAL S PARÇASI (ZOR KIVRIM)**  
**OVAL S-PIECE (HARD BEND)**

**OVAL S PARÇASI (KOLAY KIVRIM)**  
**OVAL S-PIECE (EASY BEND)**

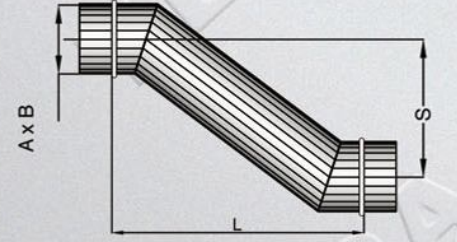
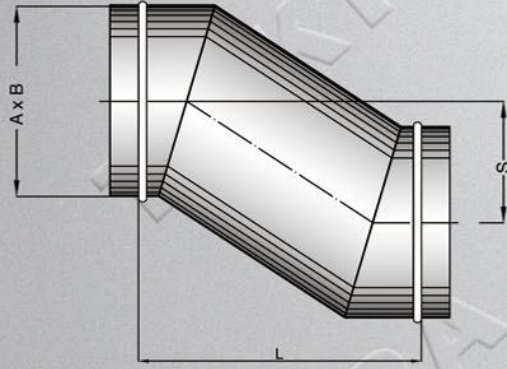

B(mm)	A(mm)
75	350
75	400
75	430
75	450
75	520
75	590
75	670
75	750
75	840
100	340
100	390
100	420
100	440
100	500
100	570
100	650
100	730
125	320
125	370
125	400
125	430
125	490
125	560
125	640
125	720
125	810
125	880
150	350
150	390
150	410
150	470
150	550
150	620
150	700
150	800
150	860
150	910
150	1030
150	1180
200	360
200	380
200	420
200	520
200	590
200	670
200	770
200	830
200	880
200	1010
200	1150
200	1310
250	350
250	420
250	490
250	570
250	640
250	740
250	800
250	850
250	980
250	1120
250	1280
250	1440
250	1630
250	1830

B(mm)	A(mm)
300	460
300	540
300	620
300	710
300	770
300	820
300	950
300	1090
300	1250
300	1410
300	1600
300	1800
300	2040
350	510
350	590
350	680
350	750
350	790
350	920
350	1060
350	1220
350	1380
350	1570
350	1770
350	2010
400	560
400	650
400	720
400	760
400	890
400	1030
400	1190
400	1350
400	1540
400	1740
400	1980

B(mm)	A(mm)
450	530
450	620
450	690
450	730
450	860
450	1000
450	1160
450	1320
450	1510
450	1710
450	1950
450	2010
500	600
500	660
500	710
500	830
500	970
500	1120
500	1290
500	1480
500	1690
500	1920
500	2080

B(mm)	A(mm)
550	630
550	680
550	800
550	940
550	1100
550	1260
550	1450
550	1650
550	1890
550	2040
600	650
600	770
600	910
600	1070
600	1230
600	1420
600	1620
600	1860
600	2010



- İstenilen uzunlukta ve kaçışta (S) imal edilir  
/ It's also possible to produce each length that customer needs
- Contalı ve contasız imalatımız mevcuttur  
/ The products can be produced with or without gasket

**OVAL SAPLAMA - YUVARLAK KENARA**  
**OVAL TAKEOFF - TO THE ROUND SIDE**

B(mm)	A(mm)
75	350
75	400
75	430
75	450
75	520
75	590
75	670
75	750
75	840
100	340
100	390
100	420
100	440
100	500
100	570
100	650
100	730
125	320
125	370
125	400
125	430
125	490
125	560
125	640
125	720
125	810
125	880
150	350
150	390
150	410
150	470
150	550
150	620
150	700
150	800
150	860
150	910
150	1030
150	1180
200	360
200	380
200	420
200	520
200	590
200	670
200	770
200	830
200	880
200	1010
200	1150
200	1310
250	350
250	420
250	490
250	570
250	640
250	740
250	800
250	850
250	980
250	1120
250	1280
250	1440
250	1630
250	1830

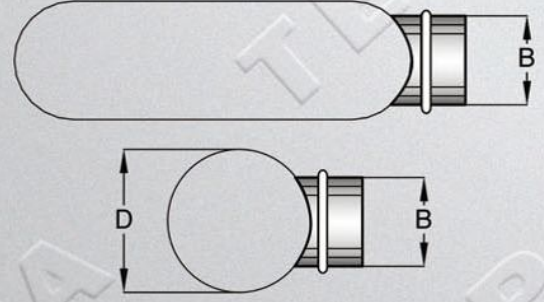
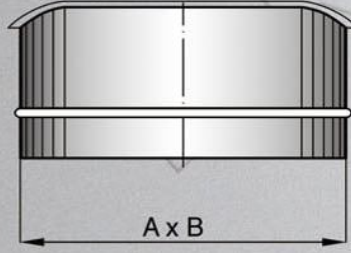

B(mm)	A(mm)
300	460
300	540
300	620
300	710
300	770
300	820
300	950
300	1090
300	1250
300	1410
300	1600
300	1800
300	2040
350	510
350	590
350	680
350	750
350	790
350	920
350	1060
350	1220
350	1380
350	1570
350	1770
350	2010
400	560
400	650
400	720
400	760
400	890
400	1030
400	1190
400	1350
400	1540
400	1740
400	1980

B(mm)	A(mm)
450	530
450	620
450	690
450	730
450	860
450	1000
450	1160
450	1320
450	1510
450	1710
450	1950
450	2010
500	600
500	660
500	710
500	830
500	970
500	1120
500	1290
500	1480
500	1690
500	1920
500	2080

B(mm)	A(mm)
550	630
550	680
550	800
550	940
550	1100
550	1260
550	1450
550	1650
550	1890
550	2040
600	650
600	770
600	910
600	1070
600	1230
600	1420
600	1620
600	1860
600	2010



• Contalı ve contasız imalatımız mevcuttur  
 / The products can be produced with or without gasket

**OVAL SAPLAMA - DÜZ KENARA**  
**OVAL TAKEOFF - TO THE FLAT SIDE**

B(mm)	A(mm)
75	350
75	400
75	430
75	450
75	520
75	590
75	670
75	750
75	840
100	340
100	390
100	420
100	440
100	500
100	570
100	650
100	730
125	320
125	370
125	400
125	430
125	490
125	560
125	640
125	720
125	810
125	880
150	350
150	390
150	410
150	470
150	550
150	620
150	700
150	800
150	860
150	910
150	1030
150	1180
200	360
200	380
200	420
200	520
200	590
200	670
200	770
200	830
200	880
200	1010
200	1150
200	1310
250	350
250	420
250	490
250	570
250	640
250	740
250	800
250	850
250	980
250	1120
250	1280
250	1440
250	1630
250	1830

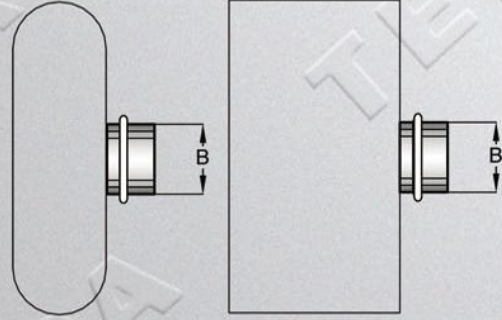
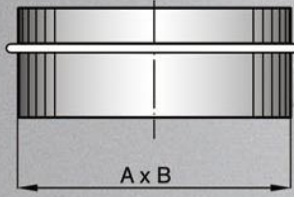

B(mm)	A(mm)
300	460
300	540
300	620
300	710
300	770
300	820
300	950
300	1090
300	1250
300	1410
300	1600
300	1800
300	2040
350	510
350	590
350	680
350	750
350	790
350	920
350	1060
350	1220
350	1380
350	1570
350	1770
350	2010
400	560
400	650
400	720
400	760
400	890
400	1030
400	1190
400	1350
400	1540
400	1740
400	1980

B(mm)	A(mm)
450	530
450	620
450	690
450	730
450	860
450	1160
450	1320
450	1510
450	1710
450	1950
450	2010
500	600
500	660
500	710
500	830
500	970
500	1120
500	1290
500	1480
500	1690
500	1920
500	2080

B(mm)	A(mm)
550	630
550	680
550	800
550	940
550	1100
550	1260
550	1450
550	1650
550	1890
550	2040
600	650
600	770
600	910
600	1070
600	1230
600	1420
600	1620
600	1860
600	2010



• Contalı ve contasız imalatımız mevcuttur  
 / The products can be produced with or without gasket



B(mm)	A(mm)
75	350
75	400
75	430
75	450
75	520
75	590
75	670
75	750
75	840
100	340
100	390
100	420
100	440
100	500
100	570
100	650
100	730
125	320
125	370
125	400
125	430
125	490
125	560
125	640
125	720
125	810
125	880
150	350
150	390
150	410
150	470
150	550
150	620
150	700
150	800
150	860
150	910
150	1030
150	1180
200	360
200	380
200	420
200	520
200	590
200	670
200	770
200	830
200	880
200	1010
200	1150
200	1310
250	350
250	420
250	490
250	570
250	640
250	740
250	800
250	850
250	980
250	1120
250	1280
250	1440
250	1630
250	1830

## OVAL KÖR KAPAK / OVAL END CAP



B(mm)	A(mm)	B(mm)	A(mm)	B(mm)	A(mm)
300	460	450	530	550	630
300	540	450	620	550	680
300	620	450	690	550	800
300	710	450	730	550	940
300	770	450	860	550	1100
300	820	450	1000	550	1260
300	950	450	1160	550	1450
300	1090	450	1320	550	1650
300	1250	450	1510	550	1890
300	1410	450	1710	550	2040
300	1600	450	1950	600	650
300	1800	450	2010	600	770
300	2040	500	600	600	910
350	510	500	660	600	1070
350	590	500	710	600	1230
350	680	500	830	600	1420
350	750	500	970	600	1620
350	790	500	1120	600	1860
350	920	500	1290	600	2010
350	1060	500	1480		
350	1220	500	1690		
350	1380	500	1920		
350	1570	500	2080		
400	560				
400	650				
400	720				
400	760				
400	890				
400	1030				
400	1190				
400	1350				
400	1540				
400	1740				
400	1980				

• Contalı ve contasız imalatımız mevcuttur  
The products can be produced with or without gasket

**TEKPA**

B(mm)	A(mm)
75	350
75	400
75	430
75	450
75	520
75	590
75	670
75	750
75	840
100	340
100	390
100	420
100	440
100	500
100	570
100	650
100	730
125	320
125	370
125	400
125	430
125	490
125	560
125	640
125	720
125	810
125	880
150	350
150	390
150	410
150	470
150	550
150	620
150	700
150	800
150	860
150	910
150	1030
150	1180
200	360
200	380
200	420
200	520
200	590
200	670
200	770
200	830
200	880
200	1010
200	1150
200	1310
250	350
250	420
250	490
250	570
250	640
250	740
250	800
250	850
250	980
250	1120
250	1280
250	1440
250	1630
250	1830

**OVAL MANŞON  
/ OVAL CONNECTOR  
(DUCT to DUCT)**



**OVAL BİLEZİK  
/ OVAL CONNECTOR  
(FITINGS to FITINGS)**

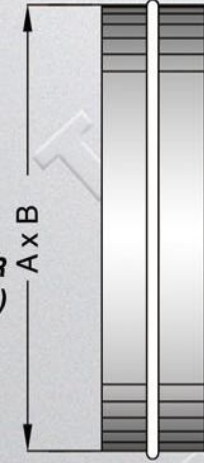

B(mm)	A(mm)
300	460
300	540
300	620
300	710
300	770
300	820
300	950
300	1090
300	1250
300	1410
300	1600
300	1800
300	2040
350	510
350	590
350	680
350	750
350	790
350	920
350	1060
350	1220
350	1380
350	1570
350	1770
350	2010
400	560
400	650
400	720
400	760
400	890
400	1030
400	1190
400	1350
400	1540
400	1740
400	1980

B(mm)	A(mm)
450	530
450	620
450	690
450	730
450	860
450	1000
450	1160
450	1320
450	1510
450	1710
450	1950
450	2010
500	600
500	660
500	710
500	830
500	970
500	1120
500	1290
500	1480
500	1690
500	1920
500	2080

B(mm)	A(mm)
550	630
550	680
550	800
550	940
550	1100
550	1260
550	1450
550	1650
550	1890
550	2040
600	650
600	770
600	910
600	1070
600	1230
600	1420
600	1620
600	1860
600	2010



• Contalı ve contasız imalatımız mevcuttur  
/ The products can be produced with or without gasket

**TEKPA**

B(mm)	A(mm)
75	350
75	400
75	430
75	450
75	520
75	590
75	670
75	750
75	840

100	340
100	390
100	420
100	440
100	500
100	570
100	650
100	730

125	320
125	370
125	400
125	430
125	490
125	560
125	640
125	720
125	810
125	880

150	350
150	390
150	410
150	470
150	550
150	620
150	700
150	800
150	860
150	910
150	1030
150	1180

200	360
200	380
200	420
200	520
200	590
200	670
200	770
200	830
200	880
200	1010
200	1150
200	1310

250	350
250	420
250	490
250	570
250	640
250	740
250	800
250	850
250	980
250	1120
250	1280
250	1440
250	1630
250	1830

**OVAL DAMPER / OVAL VOLUME DAMPER**

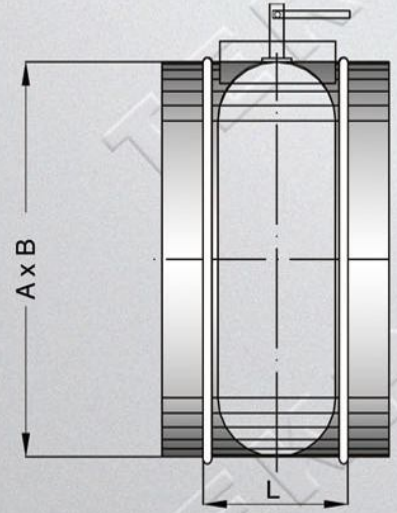

B(mm)	A(mm)
300	460
300	540
300	620
300	710
300	770
300	820
300	950
300	1090
300	1250
300	1410
300	1600
300	1800
300	2040

350	510
350	590
350	680
350	750
350	790
350	920
350	1060
350	1220
350	1380
350	1570
350	1770
350	2010

400	560
400	650
400	720
400	760
400	890
400	1030
400	1190
400	1350
400	1540
400	1740
400	1980

B(mm)	A(mm)
450	530
450	620
450	690
450	730
450	860
450	1000
450	1160
450	1320
450	1510
450	1710
450	1950
450	2010
500	600
500	660
500	710
500	830
500	970
500	1120
500	1290
500	1480
500	1690
500	1920
500	2080

B(mm)	A(mm)
550	630
550	680
550	800
550	940
550	1100
550	1260
550	1450
550	1650
550	1890
550	2040
600	650
600	770
600	910
600	1070
600	1230
600	1420
600	1620
600	1860
600	2010



• Contalı ve contasız imalatımız mevcuttur  
/ The products can be produced with or without gasket

B(mm)	A(mm)
75	350
75	400
75	430
75	450
75	520
75	590
75	670
75	750
75	840
100	340
100	390
100	420
100	440
100	500
100	570
100	650
100	730
125	320
125	370
125	400
125	430
125	490
125	560
125	640
125	720
125	810
125	880
150	350
150	390
150	410
150	470
150	550
150	620
150	700
150	800
150	860
150	910
150	1030
150	1180
200	360
200	380
200	420
200	520
200	590
200	670
200	770
200	830
200	880
200	1010
200	1150
200	1310
250	350
250	420
250	490
250	570
250	640
250	740
250	800
250	850
250	980
250	1120
250	1280
250	1440
250	1630
250	1830

## OVAL PANTOLON / OVAL Y BRANGE

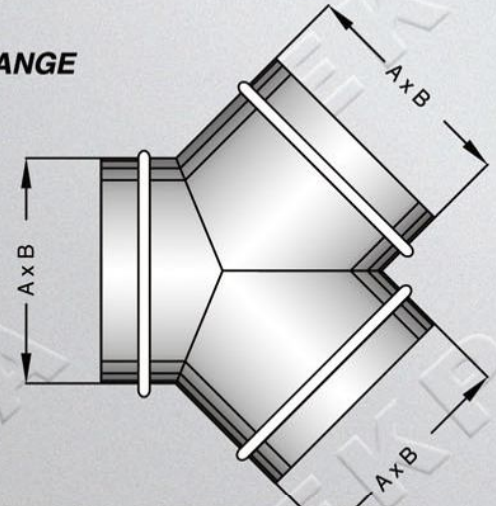

B(mm)	A(mm)
300	460
300	540
300	620
300	710
300	770
300	820
300	950
300	1090
300	1250
300	1410
300	1600
300	1800
300	2040
350	510
350	590
350	680
350	750
350	790
350	920
350	1060
350	1220
350	1380
350	1570
350	1770
350	2010
400	560
400	650
400	720
400	760
400	890
400	1030
400	1190
400	1350
400	1540
400	1740
400	1980

B(mm)	A(mm)
450	530
450	620
450	690
450	730
450	860
450	1000
450	1160
450	1320
450	1510
450	1710
450	1950
450	2010
500	600
500	660
500	710
500	830
500	970
500	1120
500	1290
500	1480
500	1690
500	1920
500	2080

B(mm)	A(mm)
550	630
550	680
550	800
550	940
550	1100
550	1260
550	1450
550	1650
550	1890
550	2040
600	650
600	770
600	910
600	1070
600	1230
600	1420
600	1620
600	1860
600	2010

**TEKPA**

• Contalı ve contasız imalatımız mevcuttur  
/ The products can be produced with or without gasket

**YUVARLAKTAN OVALE ADAPTÖR  
REDUCER - ROUND TO OVAL**

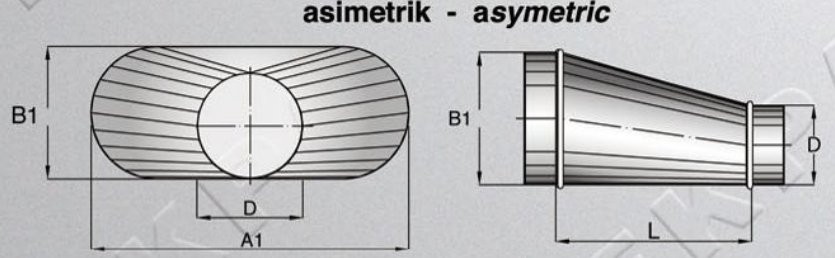
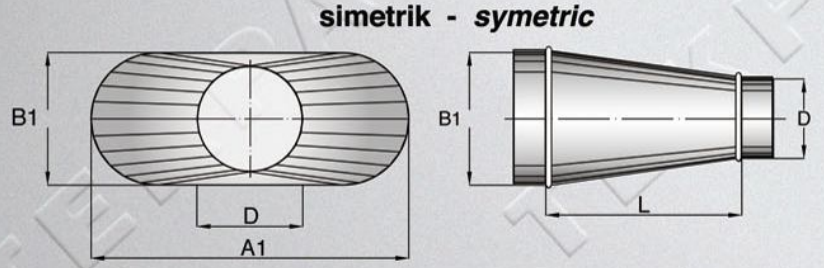

**OVALDEN OVALE REDÜKSİYON  
REDUCER - OVAL TO OVAL**

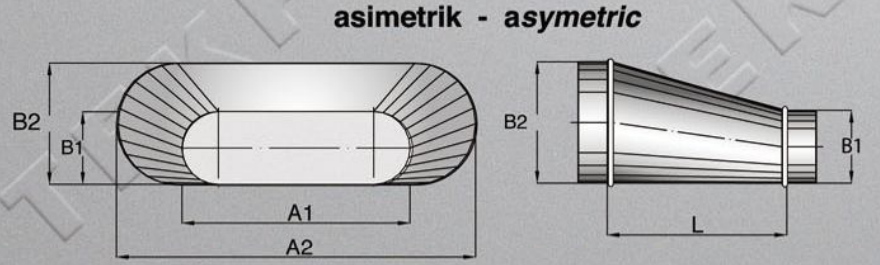
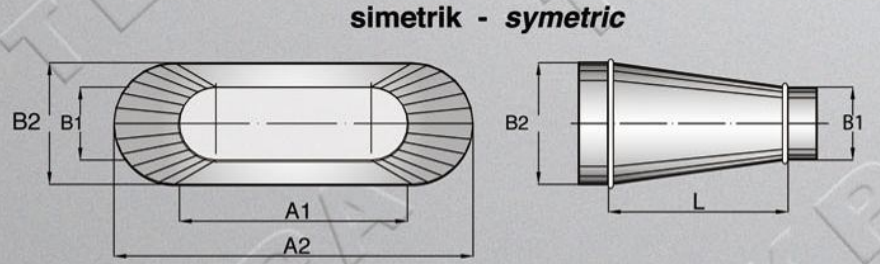

**PRİZMATİK KESİTTEN  
OVALE ADAPTÖR  
REDUCER - RECTANGULAR  
TO OVAL**

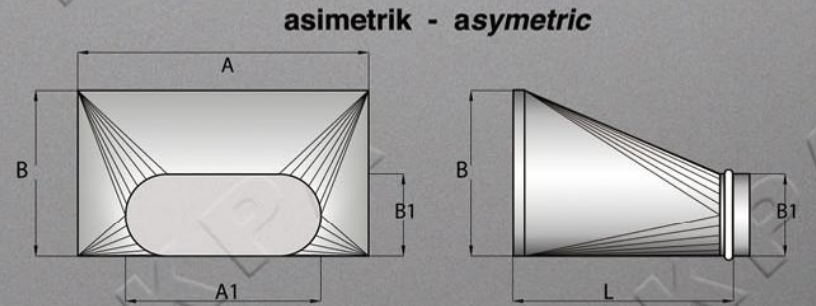
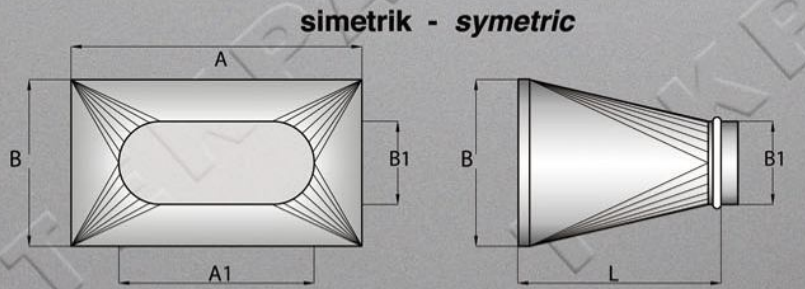

- İstenilen boy ve ebatta imalat vardır / It's also possible to produce every length, and size that customer needs.
- Contalı ve contasız imalatımız mevcuttur / The products can be produced with or without gasket

**OVAL T PARÇASI (YUVARLAK KENARA)**  
**OVAL TEE PIECE (TO ROUND SIDE)**

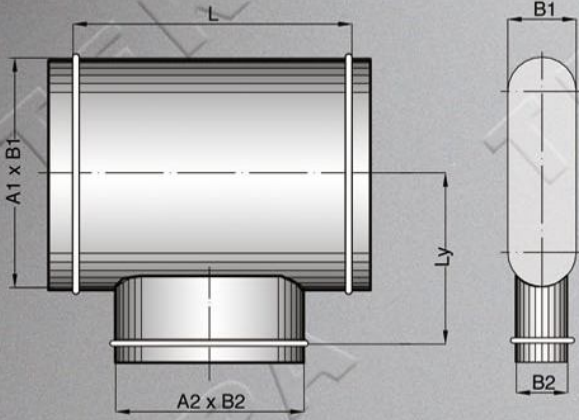

$$L = A2 + 100 \text{ mm} \quad L_y = A1/2 + 50 \text{ mm}$$

**OVAL T PARÇASI (DÜZ KENARA)**  
**OVAL TEE PIECE (TO FLAT SIDE)**

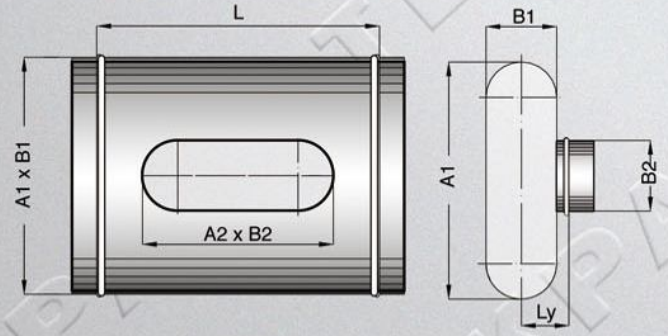

$$L = A2 + 100 \text{ mm} \quad L_y = B1/2 + 50 \text{ mm}$$

\* Bu uzunlukların dışında istenilen ebatlarda ve uzunluklarda, contalı ve contasız imal edilirler.  
/ It's also possible to produce every length, size and colour with or without gasket that customer needs.

**OVAL İSTAVROZ / OVAL CROSS**

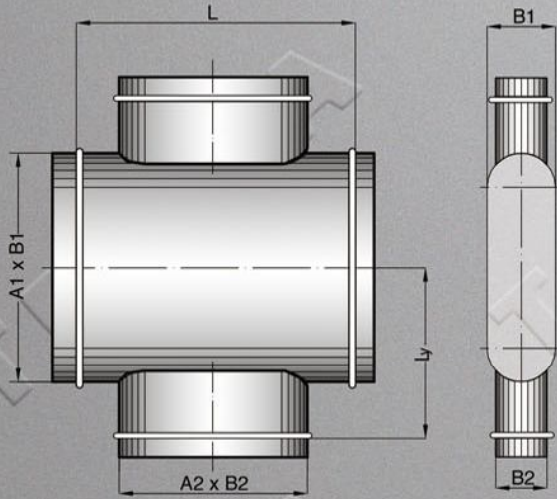

$$L = A2 + 100 \text{ mm} \quad L_y = A1/2 + 50 \text{ mm}$$

**OVAL T PARÇASI 45° / OVAL TEE PIECE 45°**

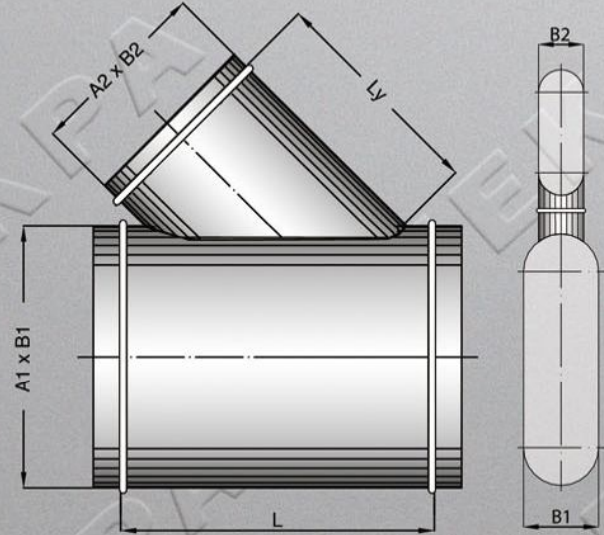

$$L = (A2 / \sin 45^\circ) + 100 \text{ mm} \quad L_y = (A2 / \tan 45^\circ) + 50 \text{ mm}$$

\* Bu uzunlukların dışında istenilen ebatlarda ve uzunluklarda, contalı ve contasız imal edilirler.  
/ It's also possible to produce every length, size and colour with or without gasket that customer needs.

**OVAL KELEPÇE / OVAL HANGER**

